

AB10 Slave Roll Sensor Installation Instructions



18881 IMMI Way
Westfield, IN 46074
imminet.com

What is the AB10 Slave Sensor and how does it work?

Depending on the vehicle configuration an AB10 Slave Sensor may be implemented in combination with an AB10 Master Sensor. The AB10 Slave Sensor receives a trigger signal from an AB10 Master Sensor and will deploy occupant protection devices.

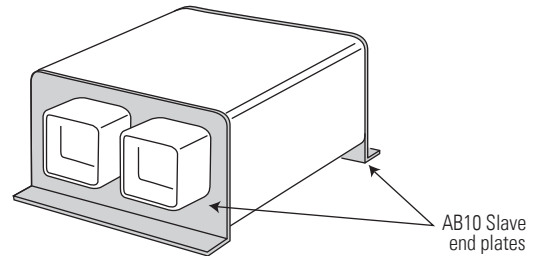

Important Facts

**PLEASE READ THIS ENTIRE GUIDE BEFORE STARTING TO INSTALL ROLL SENSOR.
PERFORM THIS PROCEDURE LAST AFTER ALL OTHER ROLL PROTECTION COMPONENTS ARE INSTALLED.**

This Roll Sensor is to be used in a specific vehicle application. Always use and follow the vehicle manufacturer's installation guide. Use this installation guide in addition to the vehicle manufacturer's guide.

1. Always disconnect vehicle batteries and turn off vehicle switch before accessing electrical connections.
2. Disconnect vehicle power before installing or servicing Roll Sensors.
3. DO NOT PUNCTURE OR DRILL ROLL SENSOR
4. Unplug Roll Sensor connectors before welding on vehicle.
5. Unplug Roll Sensor connectors before attempting to remove from vehicle. Activated Roll Sensor could deploy safety devices.
6. The unit is designed to activate once. After the system is activated or if it is damaged, the unit must be replaced by authorized personnel.

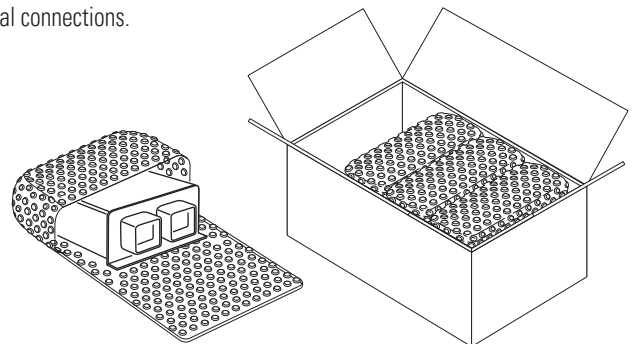

Figure 1

⚠ WARNING

DO NOT APPLY HEAT
Temperatures over 85° C (185° F)
could cause damage to the unit,
resulting in serious injury or death.

⚠ WARNING

HAZARDOUS OPERATION

Ensure power is completely removed from vehicle and tagged out until all components are securely mounted. Personnel should remain clear of components when power is first applied. Failure to do so may result in serious injury or death.

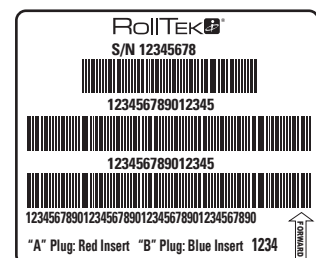

Roll Sensor Installation

Unpacking the Roll Sensor

1. Remove unit from main carton. See FIGURE 1.

Product Identification

1. Locate the product identification. This is located on the top surface of the unit. See FIGURE 2.
2. Verify your unit is the proper system for your configuration.

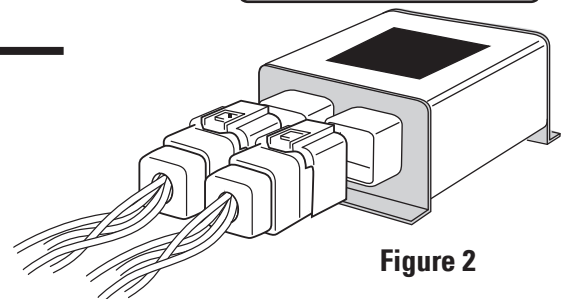

Figure 2



80274

Mounting AB10 Sensor

1. Disconnect vehicle power.
2. Use only pre-drilled mounting holes.
3. Metal to metal contact is mandatory on all mounting points.
4. Position the units in place. Make sure wiring harness is free and not pinched under unit. See FIGURE 3
5. **DO NOT MAKE WIRING HARNESS CONNECTION TO UNIT AT THIS TIME.**
6. Position the units on the mounting plate and align the holes in the mounting plate with the mounting holes on the unit. Rivet or screw unit to secure firmly in place.
7. Verify that all occupant protection devices (IHC, S4S, Buckle Pretensioner) are completely installed.
8. Verify that all cab harness connections to occupant protection devices (IHC, S4S, Buckle Pretensioner) are complete.
9. Reference OEM work instructions for additional details.
10. Verify vehicle power is disconnected and connect Roll Sensor to cab harness. Make sure connectors snap into position. Push red locking tab forward to lock connectors. See FIGURE 4. Gently tug on connector to verify locking. **DO NOT TUG ON WIRES, ONLY CONNECTOR.**
11. Exit cab. **ENSURE ALL PEOPLE ARE CLEAR OF OCCUPANT PROTECTIVE DEVICES AND SEAT SUSPENSIONS!** Reconnect vehicle power. Follow OEM work instruction diagnostic procedure to test for proper installation.
12. Once diagnostic procedure complete, reconnect vehicle power from outside cab. Verify that fault light deactivates after 10 seconds.

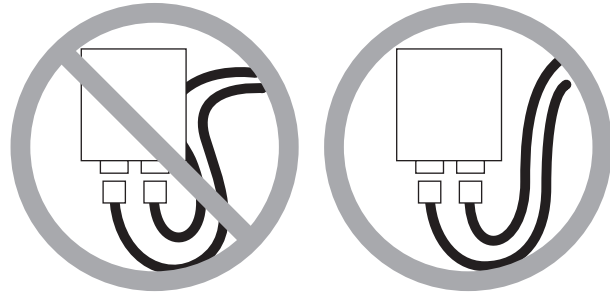

Figure 3

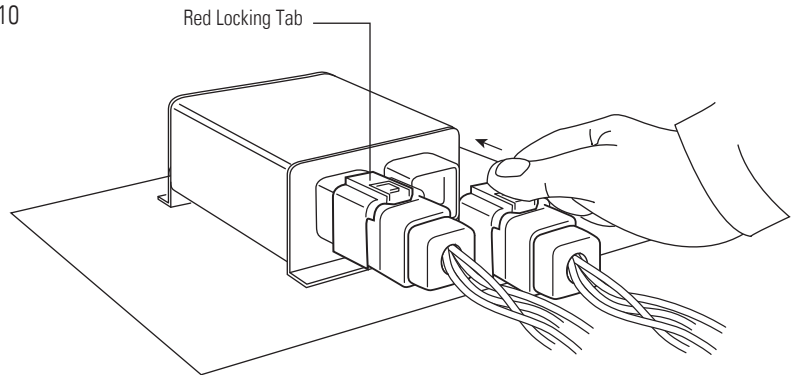

Figure 4



80274