

Vehicle Improvement Products

SmartWheel Multiplexed Steering Wheel Troubleshooting Guide

For use with:
Steering Wheels V4R-xxxxx
Controller SM211

Published: 02 December 2005
Revised: 11 April 2006



Vehicle Improvement Products SmartWheel Troubleshooting Guide

The following guide is for use with the VIP SmartWheel Series II SM211 Controller

For Software version 1.1 or higher.

The basic system operation consists of the controller providing 5 Volts DC and ground to the steering wheel switch electronics which respond with a specific combination of two voltage outputs to any switch press. The controller then decodes the values and takes the appropriate action - typically opening or closing a relay.

Troubleshooting first consists of verifying good connections through the column. This consists of verifying the clockspring connection is in good order. One simple way to test the clockspring is to rock/rotate the steering wheel right and left and see if there is intermittent operation of the steering wheel controls. Then verify battery, ignition and ground to the controller and confirm that each function works using the diagnostic mode described below. Most of the functions can be checked by using an ohmmeter on the relay contacts shown in the attached wiring diagram.

To remove or install the horn pad in order to check connection from controller to switch pods, or to check switch pods please follow the instructions at the end of this troubleshooting guide.

Normal Operating Mode:

Check the diagnostic LED (Seen through hole in controller cover.)

- Green = Ignition on, battery normal, no steering wheel switches depressed.
- Red/Orange = Valid switch detected (Appropriate function should be activated.)

Most Common Faults:

The following are examples of the most common problems and what to look for.

Problem	Cause
Marker and or Headlamps cycle on-off while in use.	Marker and or Headlamps drawing more than rated current than controller can handle. (9 amps max total for headlamps and or running lamps, and 9 amps max for marker lamps)
Wipers not functioning properly or other odd quirks in vehicle lighting or instrumentation	The most common problem with wipers and or lighting issues is poor ground(s). Please check grounds at accessories being driven by the controller (such as wiper motors, cruise control, lamps, etc.) The ground for these accessories should be tied to the nearest body/frame ground on vehicle. They should NOT use any ground(s) from the controller as their only ground.

This document is provided on a restricted basis and is not to be used in any way detrimental to the interests of Vehicle Improvement Products, Inc.

Vehicle Improvement Products SmartWheel Troubleshooting Guide

Diagnostics:

Read through the entire procedure below and then proceed as directed:

Verify battery, ignition and ground at the controller per the attached wiring diagram.

To use the built-in diagnostics on the SM211:

- Remove the J2 harness connector from the controller first, then the other three connectors.
- Tie J4.8 on the controller to +12V Bat (So 12V is present before controller power up.).
- Replace connector J1 and then J2.
- Check the diagnostic LED (Seen through hole in controller cover.)
 - Green = power on - CPU operating normally.
- Press a switch on the wheel and the LED will flash Red with ~1 sec. period. The number of red flashes corresponds to the switch pressed. (Table follows.) Note that some functions are only available with the ignition on. After the LED has flashed the switch code, the corresponding function will activate normally.

J3 & J4 can be replaced during the diagnostics for troubleshooting if needed.

If the green LED illuminates in diagnostic mode but there is no response from the steering wheel then check connections to the wheel. If the connections and the column clockspring check good, replace the switchpods on the wheel. All of the steering wheel electronics are within the switchpods.

If the green LED does not illuminate and you have verified power, ground and diagnostic mode as described then replace the controller.

If the controller responds properly to the wheel commands and the controller relays function correctly then look for issues either in the wiring between the controller and the device being controlled or with the device being controlled itself.

Once in diagnostic mode the controller will stay in diagnostic mode until the power is cycled with J4.8 either open or at ground.

To restore normal operation:

- Remove the harness connectors from the controller - J2 first.
- Return J4.8 to original state:
 - Ground for headlamps only with wipers.
 - Open for headlamps and marker lamps with wipers (most common).
- Reinstall the four harness connectors on the controller - J2 last.

Switch Position/Switch LED code:

Left Pod Button	Red LED Number of Flashes	Right Pod Button	Red LED Number of Flashes
Cruise Resume	7	Wiper Variable	2
Cruise Set	8	Wiper Wash	3
Cruise Cancel	9	Wiper Hi/Lo	4
Cruise On/Off	10	Wiper Off	5
Head Lamp Flash	11	Marker Lamp Flash	6

Note: Pressing the city horn pad button will cause the red LED to flash once.

This document is provided on a restricted basis and is not to be used in any way detrimental to the interests of Vehicle Improvement Products, Inc.

Vehicle Improvement Products SmartWheel Troubleshooting Guide

Steering wheel wire color code:

Steering Wheel Connector Cavity		
Position	Color Wire	Function
A	Violet	Switch Bank (Valid range 0 to 5 VDC)
B	Blue	Switch Value (Valid range 0 to 5 VDC)
C	White	Ground (0 V)
D	Red	Ignition (5 VDC)

Checking Proper Operation of Switch Pods:

To check proper operation of the switch pods, the output voltage per button pressed can be measured. Using a digital multimeter connect the ground lead of the multimeter to the white wire (ground) in the steering wheel connector cavity. Connect the positive lead of the multimeter to the blue wire to check voltages shown in table 1. Then connect the positive lead of the multimeter to the violet wire to check voltages shown in table 1. Be sure to apply power to the system; battery and ignition power on to make the measurements.

Notes:

- Use of an analog meter might place an additional load on the pods, reducing the voltages shown in table 1, yielding incorrect results.
- Voltages shown are nominal values, actual values might vary slightly, this is normal.

TABLE 1

Function:	Nominal Voltages:	
	Blue Wire (Value)	Violet Wire (Bank)
SW1 Horn Switch	0.020	1.692
SW2 Wiper Variable	3.708	1.377
SW3 Wiper Wash	2.942	1.377
SW4 Wiper High/Low	3.708	0.961
SW5 Wiper Off	2.286	1.377
SW6 Marker Lamp Flash	2.942	0.961
SW7 Cruise Resume	3.747	4.308
SW8 Cruise Set	3.005	3.790
SW9 Cruise Cancel	2.352	3.334
SW10 Cruise On/Off	3.708	2.250
SW11 Headlamp Flash	2.942	2.250

This document is provided on a restricted basis and is not to be used in any way detrimental to the interests of Vehicle Improvement Products, Inc.

Vehicle Improvement Products SmartWheel Troubleshooting Guide

Directions for Removing Horn Pad:

1. Remove Horn Pad by placing both hands on top of pad as shown below (Pic 1). Using your fingertips underneath the top leading edge of the horn pad (Pic 2) gently pull upward toward you. There are four posts securing the horn pad to wheel blocks, generally all four will release using the manner just described. DO NOT use a ripping motion to remove the pad, as it is possible to damage the posts. Remove the wire connected to the back of the horn pad.



Pic 1



Pic 2

This document is provided on a restricted basis and is not to be used in any way detrimental to the interests of Vehicle Improvement Products, Inc.

Vehicle Improvement Products SmartWheel Troubleshooting Guide

Directions for Installing Horn Pad:

1. Lay horn pad on top of steering wheel aligning the four posts of the horn pad directly on top of their respective mating holes. *Be sure to reconnect city horn wire lead to horn pad.* Using the palm of your hand gently tap each of the four corners of the horn pad starting with the lower right, then lower left, to upper right, finishing with upper left. (Refer to diagram 1). Do NOT attempt to snap all four retaining posts in at the same time by hitting steering wheel in center, damage may result.

Diagram 1.

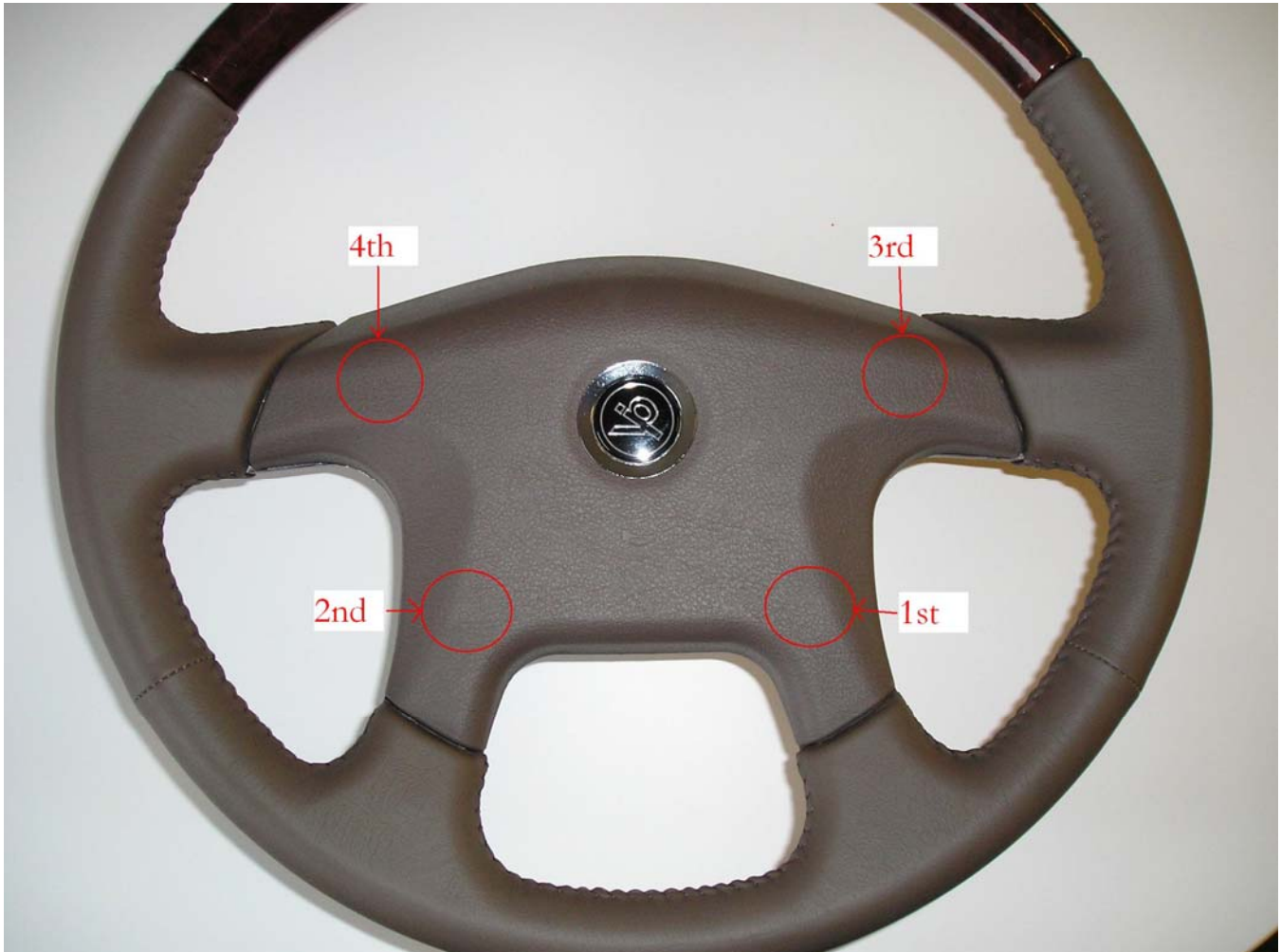

This document is provided on a restricted basis and is not to be used in any way detrimental to the interests of Vehicle Improvement Products, Inc.

SM211 Rev B Controller

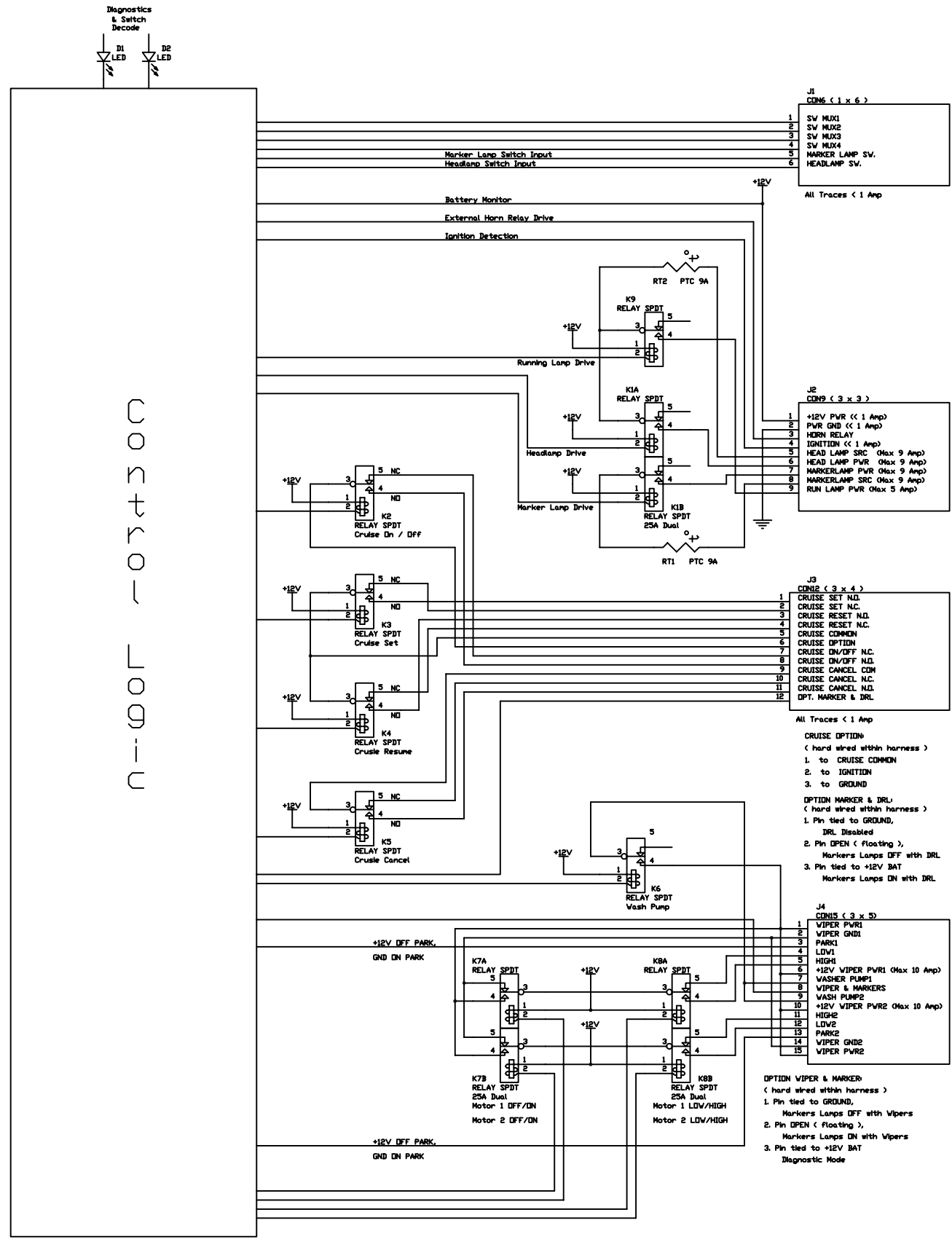

CONTROLLER

The control module is designed to mount in the passenger compartment of the vehicle. The rated operating temperature is -40 to +80 degrees C. It must not be exposed to the higher operating temperatures and moisture levels typical of the engine compartment.

Chassis Wiring

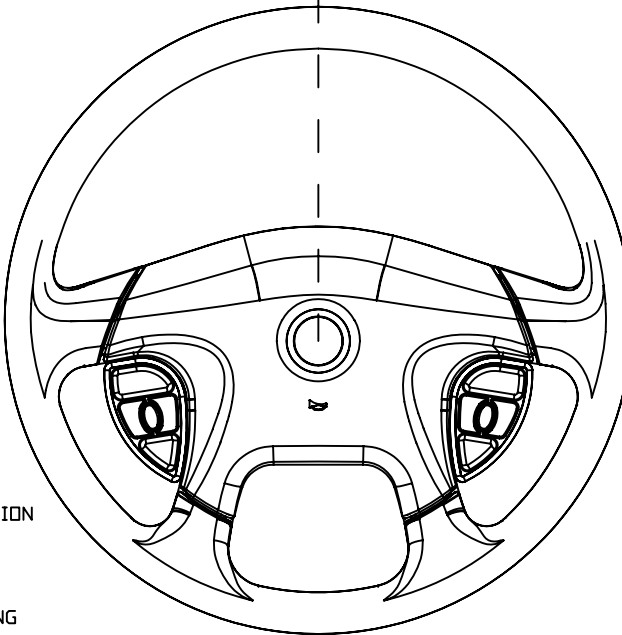
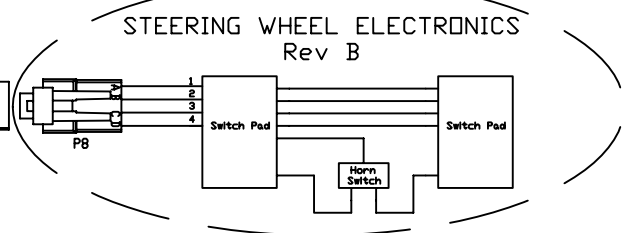
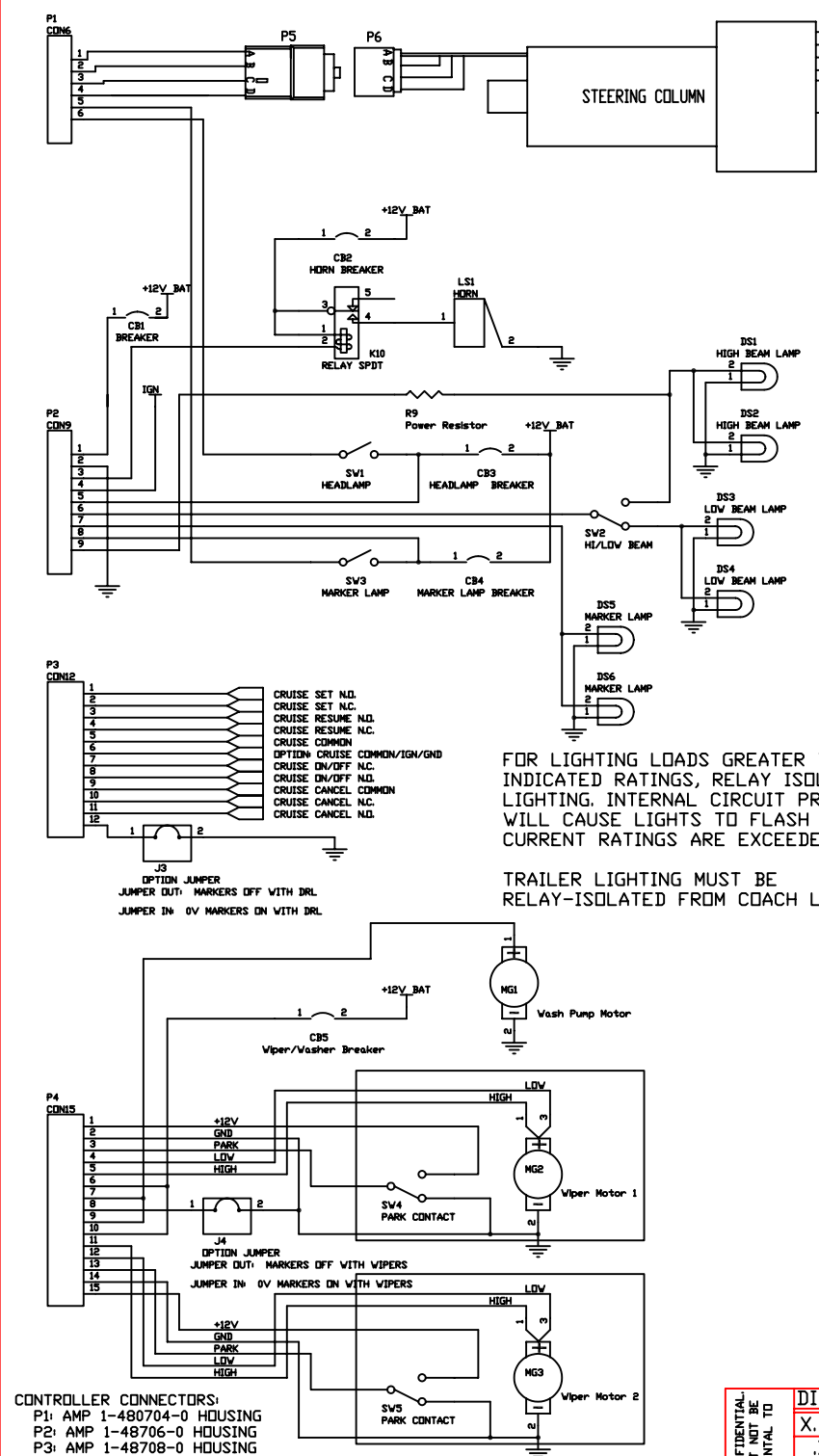

CONTROLLER CONNECTORS:
 P1: AMP 1-480704-0 HOUSING
 P2: AMP 1-48706-0 HOUSING
 P3: AMP 1-48708-0 HOUSING
 P4: AMP 1-480710-0 HOUSING
 AMP 350689-3 20-18 AWG SOCKET CONTACT
 THE VIPER CONNECTOR IS SYMETRICAL AND WORKS IN EITHER ORIENTATION.
 CHASSIS CONNECTOR:
 P5: PACKARD 12092163 HOUSING
 PACKARD 12047581 AWG 20 TERMINAL

Power ground for the wiper motor(s) must be supplied by a chassis ground to the wiper motor case(s). The ground return to the control module is for signal level reference only.

DIM	PL	ENG	MM	LTR	DESCRIPTION	DATE
X.		.060	1.524			
.X		.030	.762			
.XX		.010	.254			
.XXX		.005	.127			
ANGLES ± 2°					B Reversed Pinouts on P5 & P6	02-21-2005
					A Release	11-23-2004
VEHICLE IMPROVEMENT PRODUCTS INC.						
DRAWN BY DR		TITLE SM211 CHASSIS WIRING DIAGRAM		FILE NO. 01460		
DATE 10-11-04		SCALE NONE		DRAWING NO. MPXW006		
ANTIOCH, IL USA (847)-395-7250						

SM211/SM212 Control Box

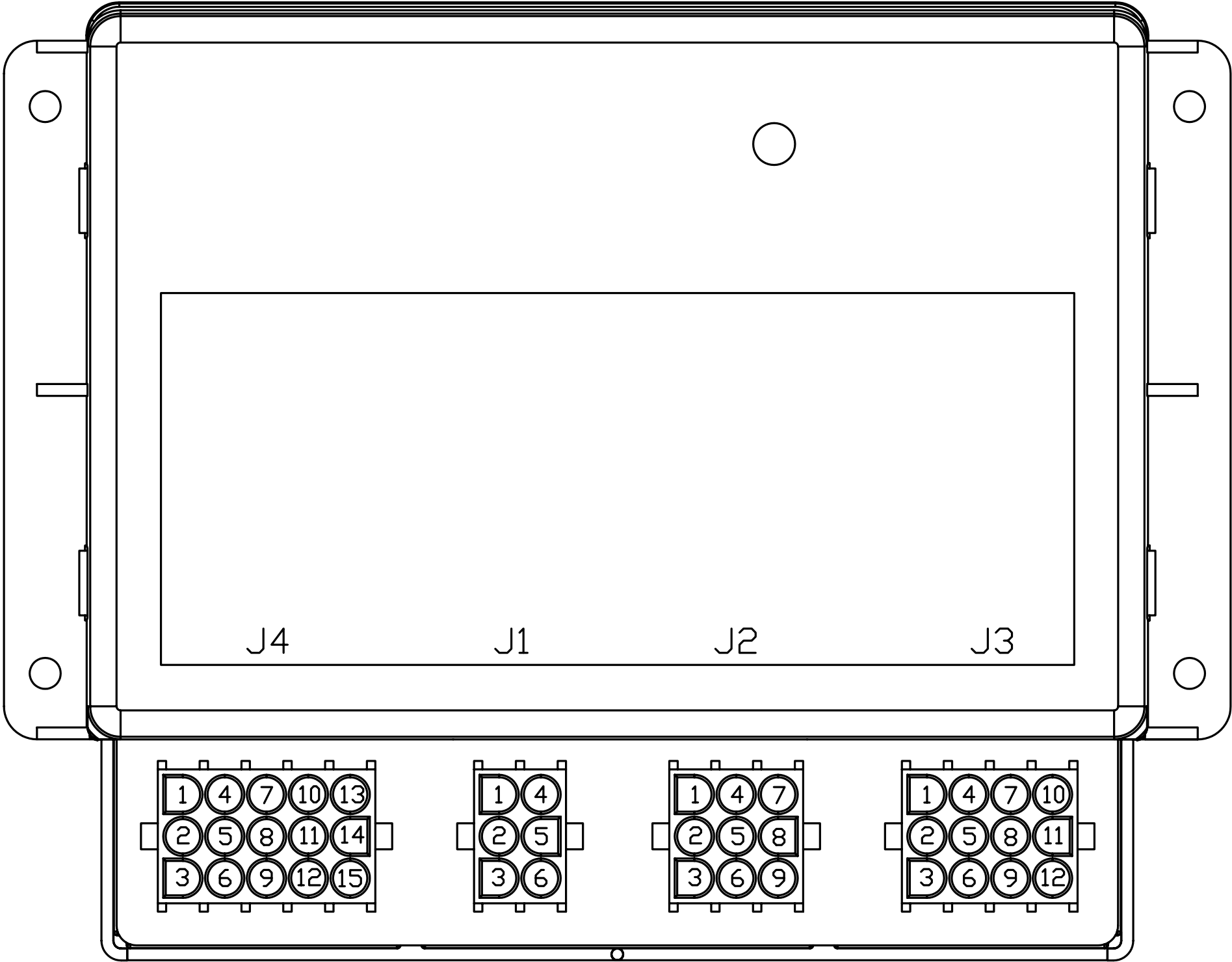

The control module is designed to mount in the passenger compartment of the vehicle. The rated operating temperature is -40 to +85 degrees C. It must not be exposed to the higher operating temperatures and moisture levels typical of the engine compartment.

DIM	PL	ENG	MM	LTR	DESCRIPTION	DATE
X.		.060	1.524			
.X		.030	.762			
.XX		.010	.254			
.XXX		.005	.127			
ANGLES ± 2°				A	Released	01-21-05
VEHICLE IMPROVEMENT PRODUCTS INC.						
DRAWN BY		TITLE		FILE NO.		
DK		SM211/SM212 PINDUT		01491		
DATE		SCALE		DRAWING NO.		
12-17-04		NONE				
ANTIPOCH, IL USA (847)-395-7250						

THIS DRAWING AND ITS INFORMATION IS CONFIDENTIAL. IT IS THE PROPERTY OF VIP INC. AND MUST NOT BE MADE PUBLIC OR USED IN ANY WAY DETRIMENTAL TO THE INTERESTS OF VIP INC.

